



# ROGOWSKI CURRENT WAVEFORM TRANSDUCERS

## INSTRUCTIONS FOR USE **CWT Mini50HF**

***POWER ELECTRONIC MEASUREMENTS Ltd.***

+44 (0)115 946 9657 • [info@pemuk.com](mailto:info@pemuk.com) • [www.pemuk.com](http://www.pemuk.com)

This document is copyright © March 2025 Power Electronic Measurements Ltd. and all rights are reserved.  
No part may be copied or reproduced in any form without prior written consent.

Mar 2025

**INTRODUCTION ..... 3**

**TECHNICAL SPECIFICATION ..... 3**

**STANDARDS AND APPROVALS ..... 5**

**MEASUREMENT CATEGORIES..... 5**

**OVERVIEW: CWT MINI50HF ..... 6**

**HANDLING INSTRUCTIONS ..... 7**

**SAFETY AND PRE-USE CHECKS ..... 8**

**POWER OPTIONS ..... 9**

**REPLACING THE BATTERY ..... 9**

**SWITCHING ON ..... 10**

**OBTAINING THE BEST MEASUREMENT ..... 11**

**CLEANING AND DECONTAMINATION ..... 12**

**WARRANTY ..... 12**

**RETURNING YOUR CWT FOR RECALIBRATION OR REPAIR ..... 12**

**END OF LIFE DISPOSAL ..... 12**

---

## INTRODUCTION

---

The CWT Mini50HF (CWT) Rogowski Current Waveform Transducer from PEM combines high bandwidth performance with minimal disruption to the circuit under test. These instructions must be followed whenever the unit is used. They are intended to help you obtain the best and safest performance from the transducer. Retain these instructions in a safe place for future use.

Throughout these instructions there are a number of warnings which must be observed to ensure safe operation of this unit. These warnings are identified by the following symbol:



The intended use is for the measurement of AC current. PEM accepts no responsibility for any damage resulting from careless use, or failure to observe these instructions.

PEM shall not be liable for any consequential damages, losses, costs or expenses arising from the use or misuse of this product however caused.

---

## TECHNICAL SPECIFICATION

---

<b>Peak Current</b>	Refer to ID Label
<b>Peak Output Voltage</b>	$\pm 6V$ (corresponding to $\pm$ Peak Current Rating)
<b>Output Cable</b>	0.5m BNC 50 $\Omega$ cable  Functional Earth. It is recommended that the BNC terminal be connected to earthed equipment.
<b>Output Load</b>	$\geq 100k\Omega$ (for rated accuracy – recommend DC1M $\Omega$ on scope) $= 50\Omega$ (CWT can drive a 50 $\Omega$ load if necessary)  NB. A load of 50 $\Omega$ will reduce the CWT sensitivity by half its normal value <b>and</b> limit the peak output voltage to $\pm 2V$ .
<b>Bandwidth (-3dB)</b>	Refer to the datasheet
<b>Operating Temp. Range</b>	0 $^{\circ}C$ to +40 $^{\circ}C$ ( <i>Integrator electronics</i> ) -40 $^{\circ}C$ to +125 $^{\circ}C$ ( <i>Coil and cable</i> )
<b>Measurement Category</b>	2kV Coil: CAT III 300V, 2kV Peak 5kV Coil: CAT III 600V, 5kV Peak
<b>Absolute di/dt Ratings</b>	100kA/ $\mu s$ (peak)   1.2kA/ $\mu s$ (rms)

<b>Accuracy (typ.)</b>	<b>(5% to 100% Peak Current)</b>
Calibration	Nominally $\pm 0.2\%$ with the conductor central in the Rogowski loop. See the calibration certificate for further details.
Positional Accuracy	$\pm 2\%$ variation of accuracy with conductor position in the loop (see 'Obtaining The Best Measurement')
Linearity	$\pm 0.05\%$ of reading
Noise (Typ)	Refer to datasheet
<b>Coil Bend Radius</b>	15mm
<b>Environmental</b>	Indoor use / Altitude up to 2000m Pollution Degree 2. Max. Rel. Humidity: 80% up to 31°C Decreasing Linearly to 50% at 40°C
<b>Operation with External Adaptor</b>	
DC Supply Voltage	12Vdc ( $\pm 10\%$ )
DC Quiescent Current	60mA @12VDC – 'B' version Standard Alkaline Battery 130mA @12VDC – 'R' version NiMH Rechargeable Battery
DC Socket Type	1.3mm x 3.5mm Jack Socket – Centre Positive Tip
Adaptor Supply Voltage	100 – 240VAC
Adaptor Supply Frequency	50 - 60Hz
Adaptor Supply Current	450mA Max @ 100VAC Input
Supply Voltage Fluctuation	up to 10%
<b>PEM Recommends FRIWO, FW8002/12 available from PEM or authorised distributors.</b>	
<b>Operation with Battery</b>	
Battery Supply	'B' version: 4 x 1.5V AA alkaline Battery Life: 25hrs typ.  'R' version: 4 x 1.2V NiMH rechargeable batteries Battery Life: 10hrs typ. (based on a 1400mAh cell) Typical Recharge Time: 40 hrs

---

## STANDARDS AND APPROVALS

---

---

<b>EMC Approvals</b>	EN61326-1:2021 FCC Title 47 (CFR:2010, Part 15b)
----------------------	---

---

---

<b>Safety Approvals</b>	EN61010-1:2010 EN61010-2-032:2012
-------------------------	--------------------------------------

---

---

<b>Quality System</b>	IS09001:2015
-----------------------	--------------

---



---

## MEASUREMENT CATEGORIES

---

---

<b>Category</b>	<b>Location</b>
II	For measurements performed on MAINS socket outlets and similar points in the MAINS installation.
III	For measurements performed on the MAINS distribution parts of a building.
IV	For measurements performed on the source of the MAINS installation.

---

## OVERVIEW: CWT MINI50HF

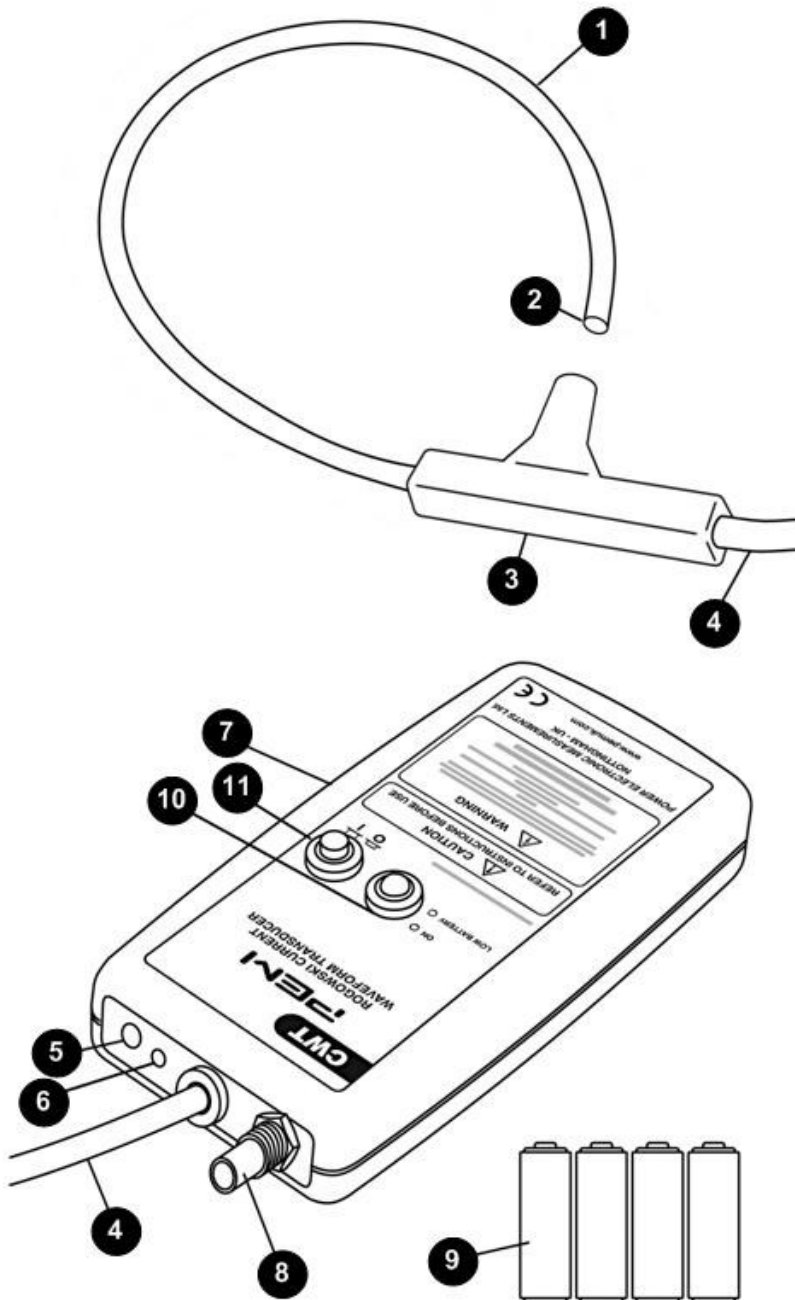

1. Rogowski Coil (Probe)
2. Probe 'Free End'
3. Ferrule
4. Connecting Cable
5. DC Power Socket
6. DC Power Status LED
7. Enclosure
8. 0.5m fixed BNC output cable terminated in BNC plug.(Not Shown)
9. 4 x AA batteries
10. Status Indicator LED  
GREEN = ON  
RED = Battery LOW
11. Power Button

---

## HANDLING INSTRUCTIONS

---

Every effort has been made to ensure that the CWT Mini50HF is as robust as possible. To prolong the life of the coil please observe the following handling instructions.

### Releasing The Coil

The free end of the coil is unclipped by applying gentle pressure in the direction shown.

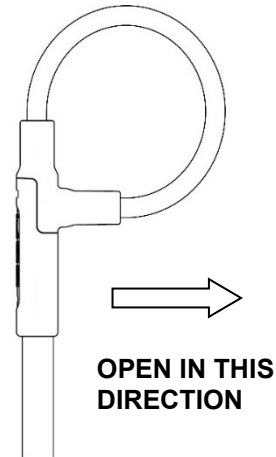

### Correct Coil Insertion

The coil is correctly positioned when the free end of the coil is fully inserted into the ferrule.

When correctly inserted, the ferrule will grip the coil and hold it securely.

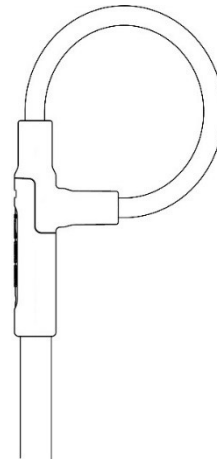

Never force the free end of the coil into the ferrule. This may damage the coil insulation.



Take care not to put any force onto the cable attached to the coil. This may damage the coil.



When not in use return the CWT coil to its protective case.



The minimum bend radius of this coil is 15mm. This is the minimum radius that the coil can be bent without risk of damaging the coil or shortening its life.

---

## SAFETY AND PRE-USE CHECKS

---



The CWT does not provide protection of the user from electric shock whilst applying or removing the probe from HAZARDOUS LIVE conductors.

The probe must only be applied to or removed from **de-energised circuits**.

The Rogowski coil must not be used if the coil is damaged.

If the CWT is used in a manner not specified by the manufacturer the protection provided by the equipment may be impaired.

### THE CWT MINI50HF ROGOWSKI COIL



The integrity of the insulation around the Rogowski coil itself must be VISUALLY INSPECTED before use, and the transducer must NOT BE USED if there are signs of damage.



When bending the flexible coil around a conductor, avoid tight bends and sharp edges that could damage the coil.



The safe PEAK working voltage of the Rogowski is clearly labelled on the coil. Never use at voltages greater than this value.



Voltage ratings are only valid if the 'free-end' of the coil is fully inserted into the socket and remains fully inserted during use. The coil has a friction fit, the coil is fully inserted when the user feels they can ease the coil free end into the ferrule no further.



The voltage ratings of the Rogowski coil are appropriate for intermittent use of the CWT as a test instrument and not for continuous use in a permanent installation.

The ratings are derived from the following standard test: Coils rated for 2kV peak are tested for one minute at 3.8kVrms using a 50Hz sine-wave voltage, those rated for 5kV peak are tested at 8kVrms.

For permanent installation the coil should be situated such that corona, which will eventually damage the coil insulation, cannot occur. For information regarding permanent installation of PEM's Rogowski coils on high voltage equipment please consult PEM.



The user must ensure that the absolute maximum rated di/dt is not exceeded

### THE INTEGRATOR



Although not relied upon for safety, PEM recommend that the unit is properly grounded to the connected monitoring equipment via the BNC output lead.

---

## POWER OPTIONS

---

The CWT can be powered by an external DC source or by one of two battery options. The battery option is displayed along with the model type on the serial number label and will state either standard non-rechargeable batteries **[B]** or rechargeable option **[R]**

### External Supply

The CWT can be powered by an external DC supply. The DC voltage must be 12V( $\pm 10\%$ ) using a suitably sized, centre positive connector. When the DC supply is present a RED indicating LED adjacent to the socket is illuminated.

### Standard Alkaline Batteries

Four fully charged AA alkaline batteries provide approx. 25 hours operation. Healthy batteries are indicated by the GREEN LED. If the LED is RED the batteries are depleted and must be replaced.

When the DC voltage is present the batteries are inoperative.

### Rechargeable Batteries

Four fully charged rechargeable AA cells provide approx. 10 hours operation. Healthy batteries are indicated by the GREEN LED. If the LED is RED the batteries are depleted and must be replaced or recharged.

When the DC supply is present the batteries are inoperative and the external DC voltage powers the transducer. In addition, when the DC supply is present (regardless of whether the transducer is ON or OFF) the rechargeable batteries are trickle-charged.

---

## REPLACING THE BATTERY

---

Low battery is indicated by a red LED located near the power switch. To replace the battery, switch off the transducer, remove the battery cover and replace with appropriate batteries for your model type.

Alkaline batteries that are deeply discharged are more prone to leaking. PEM strongly advise that for long-term storage, the batteries are removed from the instrument.

The circuit under test must be **de-energised** or the probe is removed from the test circuit before replacing the batteries.

---

## SWITCHING ON

---



Before installing the CWT and taking a measurement refer to SAFETY AND PRE-USE CHECKS and HANDLING INSTRUCTIONS to ensure safe operation of your CWT.



The probe must only be applied to or removed from **de-energised** circuits.

1. Connect the BNC output lead of the transducer to the appropriate oscilloscope or other monitoring equipment.

Although not relied upon for safety, PEM recommend that the unit is properly grounded to the connected monitoring equipment via the BNC output lead.

2. Having carried out the VISUAL INSPECTION of the Rogowski coil, unclip the coil and wrap it around the **de-energised** conductor under test.
3. Insert the free end of the coil fully inside the ferrule.
4. Re-energise the conductor.
5. Use the push-button to switch ON by pressing and releasing the button, and to turn OFF by depressing the button fully; the LED indicates that the transducer is ON when the LED is GREEN.
6. After switch-on the CWT may require a settling period of up to 2 minutes before providing an accurate measurement. The settling period is dependent on warm-up time and the low frequency bandwidth.
7. PEM recommend that the integrator is kept well away from any strong sources of electromagnetic interference when taking measurements.

---

## OBTAINING THE BEST MEASUREMENT

---

The Rogowski coil should be positioned so that the conductor under test is encircled by the coil but is not adjacent to the cable attachment (see picture below). Arrows near the ferrule indicate the direction a positive current should flow through the coil loop in order to obtain a positive output voltage. The CWT has been calibrated with the conductor near the centre (position **A**), and this is the ideal position for accuracy.

For the best high frequency performance, the centre of the current should lie on the line shown **A** to **B**, where **B** is halfway around the circumference of the coil.

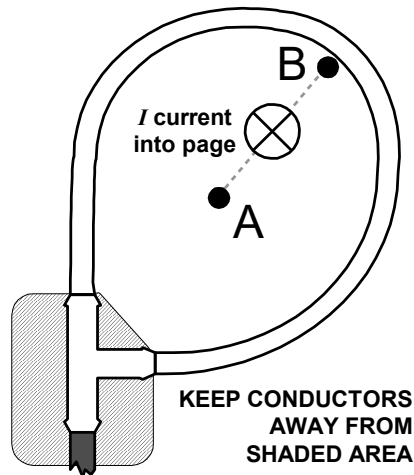

## SENSITIVITY TO EXTERNAL CURRENTS AND VOLTAGES

The sensitivity of the CWT to currents that are outside the closed loop of the Rogowski coil is very small, provided that the external currents are less than the current rating of the transducer or that such currents are relatively distant from the coil. In the vicinity of a multi-turn conductor the effects are far stronger than from a single conductor carrying the same current, and such positions should be avoided.

If there is a surface with a high voltage very close to the coil and the voltage is subject to high rates of change (e.g.  $1\text{kV}/\mu\text{s}$ ) or high frequency oscillations in the MHz range, then measurement error can arise due to capacitive coupling to the coil. However, in the case of the CWTMini50HF the Rogowski coil is fitted with an electrostatic screen underneath the coil insulation. This provides excellent immunity to fast transient voltages and greatly attenuates any electrostatic interference.

To check for any unwanted response to adjacent fields, it is recommended to quantify the output of the CWT when close to (but not encircling) the conductor under test. This will reveal the magnitude of any unwanted responses to currents close to, but outside, the coil.

## OUTPUT CABLES

The CWTMini50HF is fitted with a permanently connected BNC output cable for direct connection to the measuring instrument.

---

## **CLEANING AND DECONTAMINATION**

---

To prevent surface contamination the Rogowski coil and cable should be inspected regularly.

The CWT must be disconnected from any external circuit and turned OFF prior to cleaning.

To clean the coil and cable use a mild detergent and a damp cloth to remove any contamination, wipe dry with clean cloth to remove the detergent and dry thoroughly before placing back into service.

PEM accepts no responsibility for the use of any other cleaning solvents or cleaning methods.

---

## **WARRANTY**

---

The coil is guaranteed to be free from defects due to materials and workmanship for 12 months and the integrator for 24 months from the date of despatch from Power Electronic Measurements Ltd.

In the event of a defect where the transducer has not been misused the CWT should be returned to PEM with all freight charges to be paid by the customer. Correction shall be in the form of repair or replacement.

Power Electronic Measurements Ltd shall not be liable for any consequential damages, losses, costs or expenses arising from the use or misuse of this product however caused.

---

## **RETURNING YOUR CWT FOR RECALIBRATION OR REPAIR**

---

To return the CWT for repair or recalibration please contact PEM in advance for shipping instructions by emailing [service@pemuk.com](mailto:service@pemuk.com) or visit our website, <http://www.pemuk.com/> for contact details and our returns procedure.

---

## **END OF LIFE DISPOSAL**

---

Once your probe reaches end of life it must be disposed of responsibly and recycled. The unit must not be disposed of with household waste.

---

For technical updates and the latest product releases please consult

***POWER ELECTRONIC MEASUREMENTS Ltd.***

Gloucester House, 162 Wellington Street, Long Eaton, Nottingham, NG10 4HS, U.K.  
+44 (0)115 946 9657 • [info@pemuk.com](mailto:info@pemuk.com) • [www.pemuk.com](http://www.pemuk.com)