

CWTLF

A wide-band AC current probe optimised for lower frequency measurements, it has a BNC output to connect to most types of oscilloscope or data acquisition devices.

The CWTLF is a flexible, clip-around Rogowski probe with an extended low frequency bandwidth. This makes it ideal for power frequency and harmonic current analysis, measuring long duration pulses, or measuring large magnitude fault currents with frequency components of just a few Hz.



Measuring capacitor discharge



Different coil lengths available



Key Features

- Predictable phase response from **sub-Hz to > 100kHz**.
- **Low droop** distortion for measuring long current pulses.
- High frequency operation into **MHz**.
- Current ratings from **300A pk to 300kA pk**.
- Standard coil length of **300mm to 1000mm**, but longer coil lengths readily available.
- Coil insulation **10kV pk**.
- **Electrostatic shielded** Rogowski coils to attenuate interference from **50/60Hz** voltage sources and fast voltage transients.



Applications

- Power frequency 50/60Hz measurements and higher order harmonics.
- Measuring large currents at very low frequency such as motor/generator fault or short circuit currents. There is no de-rating at low frequency compared to current transformers.
- Pulsed currents, and pulsed power measurements with longer duration pulses.
- Measuring small AC currents in the presence of large DC currents (e.g. monitoring capacitor ripple).
- Measuring currents in difficult to reach conductors such as tightly packed bus-bars.

CWTLF Models

Model	Sensitivity (mV/A)	Peak Current* ¹ (A)	Noise* ² (mVp-p)	Droop (%/ms)	LF (-3dB) (Hz)	Peak di/dt (kA/μs)	HF (-3dB) Bandwidth* ³ (MHz)	
							300mm	700mm
CWTLF/1	20	300	15	0.47	0.5	2.5	1.6	0.75
CWTLF/3	10	600	15	0.24	0.25	5.0	1.6	0.75
CWTLF/6	5.0	1.2k	15	0.19	0.2	10	1.6	0.75
CWTLF/15	2.0	3.0k	15	0.09	0.1	11	1.6	0.75
CWTLF/30	1.0	6.0k	15	0.045	0.05	11	1.6	0.75
CWTLF/60	0.5	12.0k	15	0.018	0.02	11	1.6	0.75
CWTLF/150	0.2	30.0k	15	0.009	0.01	20	3.2	1.5
CWTLF/300	0.1	60.0k	10	0.007	0.008	20	3.2	1.5
CWTLF/600	0.05	120.0k	5.0	0.007	0.008	20	3.2	1.5
CWTLF/1500	0.02	300.0k	4.0	0.007	0.008	20	3.2	1.5

*1 Higher Peak current than 300kA pk available on request.

Lower Peak current measurements with optimised low frequency performance, see the LFR range.

*2 'Noise' is the internally generated integrator noise, this is predominantly the same frequency as the LF (-3dB) bandwidth.

*3 The HF(-3dB) is quoted for a 2.5m cable.

di/dt ratings

These are 'Absolute maximum di/dt ratings' and values must not be exceeded

Type	Abs. Max. peak di/dt	Abs. Max. rms di/dt
CWTLF/1 to CWTLF/60	11kA/μs	0.8kA/μs
CWTLF/150 and above	20kA/μs	0.8kA/μs

Output

±6V pk corresponding to 'Peak Current' into $\geq 100\text{k}\Omega$ (recommended e.g. DC1M Ω oscilloscope).
The CWTLF is not recommended for driving a 50 Ω load

Accuracy

Calibrated to $\pm 0.2\%$ reading with conductor central in the Rogowski coil loop.
Conductor position in the coil (for a 10mm dia. conductor) typically $\pm 1\%$ reading.
Linearity (with current magnitude) 0.05% reading.

DC offset

$\pm 3\text{mV}$ max. at 25°C

Temperature

Coil and cable -20°C to +100°C
Integrator electronics 0°C to +40°C

Coil voltage

10kV pk -- Safe peak working voltage to earth.
Rating established by a 15kV rms, 50Hz, 60sec voltage withstand test.

The CWTLF coil includes a removable silicone sleeve which provides additional robust mechanical protection.

Cable length

1m, 2.5m or 4m (length of cable from coil to electronics).
Longer cables are available on request.

Coil length

300mm, 500mm, 700mm or 1000mm.
Longer coils are available on request.

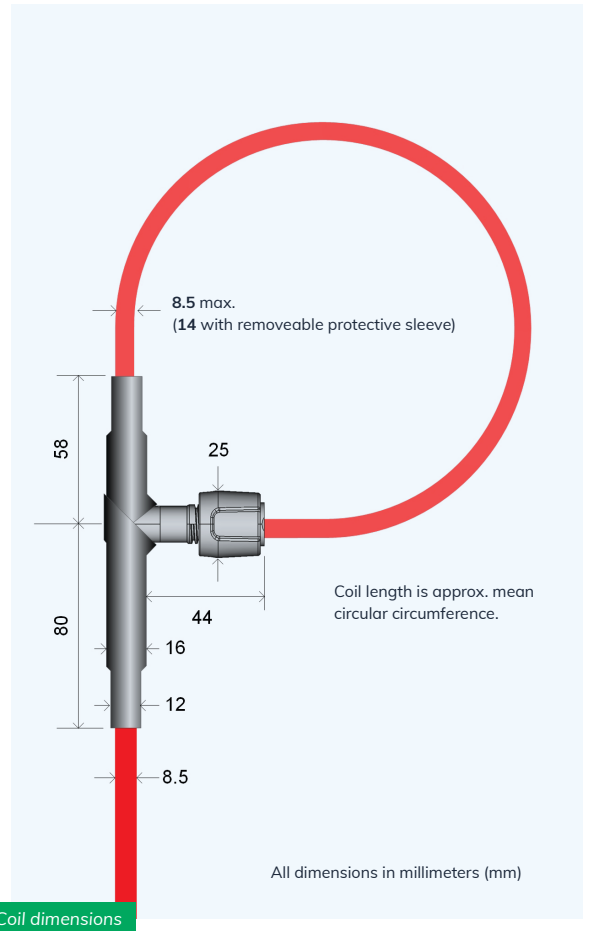

Battery Options

- B Alkaline Batteries** -- 4 x 1.5V AA alkaline batteries (70 hours).
External power adaptor disconnects batteries and powers unit.
- R Rechargeable Batteries** -- 4 x 1.2V NiMH batteries (30 hours).
External power adaptor trickle charges batteries and powers unit.

External power adaptor available in **US, EURO, UK & AUS** versions as an optional extra.

① ② ③ ④ ⑤
CWTLF / 6 / R / 2.5 / 700

Example part codes

CWTLF/6/R/2.5/700

CWTLF peak current 1.2kA, Rechargeable batteries, 2.5m cable, 700mm circumference coil, 10kV pk, 8.5mm thick coil.

CWTLF/15/B/1/500

CWTLF peak current 3.0kA, Alkaline batteries, 1m cable, 500mm circumference coil, 10kV peak, 8.5mm thick coil.

Generating the part code

- ① **Model**
- ② **Range**
- ③ **Battery Option**
- ④ **Cable Length (m)**
- ⑤ **Coil Length (mm)**

Included as standard

- ✓ Carry Case
- ✓ Unit Model
- ✓ Batteries (B or R)
- ✓ 0.5m BNC Output Cable
- ✓ Calibration Certificate

Optional Extras

- + Longer Cable
- + Longer Coil
- + Power Adaptor (UK, EU, US, AU)



More detailed technical notes, dimensioned drawings, CAD files and quotation request for this product are available online.

PEN1

Power Electronic Measurements

+44 (0)115 946 9657

info@pemuk.com

Power Electronic Measurements Ltd
Gloucester House
162 Wellington Street
Long Eaton
Nottingham
NG10 4HS
United Kingdom

www.pemuk.com

Rev. 10/25

