



Thin, flexible, clip-around 3 phase ac current transducer

RCTi[®]-3ph

The **RCTi-3ph** is an industrially specified ac current transducer for permanent installation. The coil sensors are thin, lightweight, flexible and clip-around. The output for each phase is an instantaneous voltage proportional to the measured current.

Typically the **RCTi-3ph** is used with oscilloscopes, data acquisition cards, power analyzers and meters and in power quality applications.

The **RCTi-3ph** is an ideal replacement for medium / large current, current transformers (CT's).



- **easy to retrofit** - the coil is small, light weight, and its length can be specified independently of the size of measured current
- **does not suffer from magnetic saturation**
- **non intrusive** - the coil draws no power from the circuit under test
- **no danger of open circuit secondaries**
- **low phase shift** at power frequencies (50/60Hz) and above
- **wide-bandwidth 0.6Hz to 800kHz** for measurement of sub and higher frequency harmonics and complex waveforms
- **a single enclosure and power supply cable for three channels**

Specifications

Rated current	500 A
	1,000 A
	2,500 A
	5,000 A
	10,000 A
	25,000 A
Rated Output (Full scale FS)	500,000 A
	1,000,000 A
	2,500,000 A
	5,000,000 A
	10,000,000 A
	25,000,000 A
Output limit	±5.0Vrms (±7.07V peak)
Output limit	150% FS (±10.6V peak)
Supply voltage	12Vdc (-10%) at 150mA -to-
Wide supply range	24V (+20%) at 50mA
Operating temperature range	-5°C to +65°C
Bandwidth (-3dB)	0.6Hz to 800kHz
Phase shift @ 50Hz	0.9±0.1 degrees
Accuracy	±1.0% of reading (5% to 150% FS, 25°C)
Temperature coefficient	-0.01 (coil) ±0.012 (integrator) % / °C
Output load	> 10.0kΩ

Features

- **Traceable calibration**
 - Every transducer is supplied with traceable calibration at 50Hz
 - Due to the excellent linearity of Rogowski coils (<0.05%) the calibration is maintained throughout the current range
- **Fully isolated measurement**
 - Power supply isolated to 1kVrms
 - Rogowski coil insulated to 2kV peak. Established by a standard 'flash test' at 4kVrms, 50Hz for 60 seconds
- **Easy to install, flexible, 'clip-around' coil sensor available in three standard lengths**
 - 300mm (11.8"), 500mm (19.7") and 700mm (27.6")
 - Custom lengths available on request
- **1m cable connecting the coil to the electronic integrator**
 - Custom lengths available on request
- **Small DIN rail or panel mount electronics enclosure**

Customising the RCTi-3ph

For specifications outside those detailed on the specification sheet please contact PEM e.g.

- Phase error requirements at different frequencies
- Extended coil / cable lengths
- Further current / output ratings
- Customised frequency response

Standards and Approvals

- CE Marked
- Complies with EN 61010:2001
- PEM Ltd is an ISO9001:2000 registered company
- EMC EN 61326



Connections

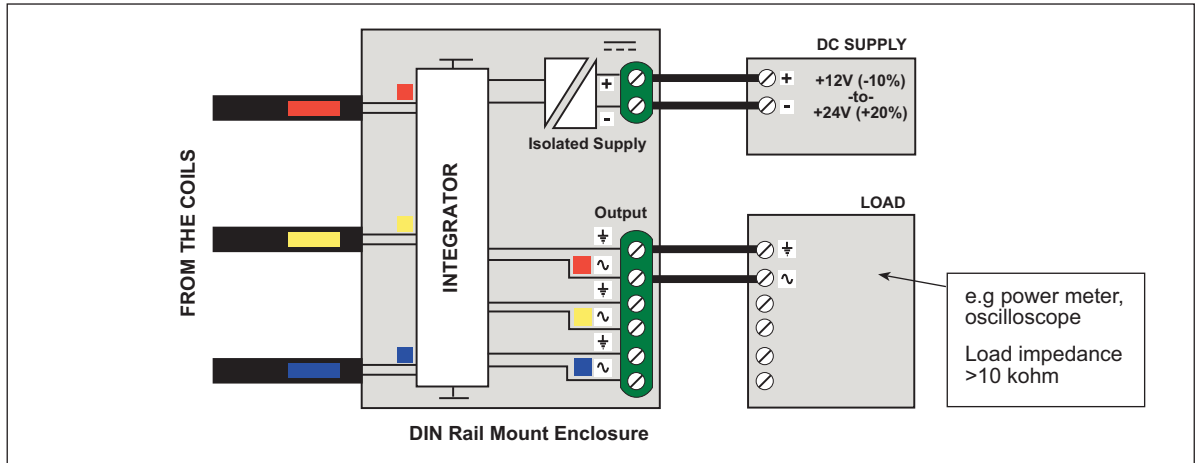

Order Code

RCTi-3ph /	□	/	□ □ □
	↓		↓
	Current range		Coil length
	2 - 500 A		300 - 300 mm
	3 - 1000 A		500 - 500 mm
	4 - 2500 A		700 - 700 mm
	5 - 5000 A		
	6 - 10000 A		
	7 - 25000 A		
	8 - 50000 A		

For example a RCTi-3ph / 5 / 700 has a current rating of 5000A and a 700mm (27.6") circumference Rogowski coil. It requires a +12 (-10%) to +24V(+20%)V dc supply.

Customised versions are available on request. If your requirement is outside that listed in this datasheet please contact Power Electronic Measurements Ltd.

Dimensions

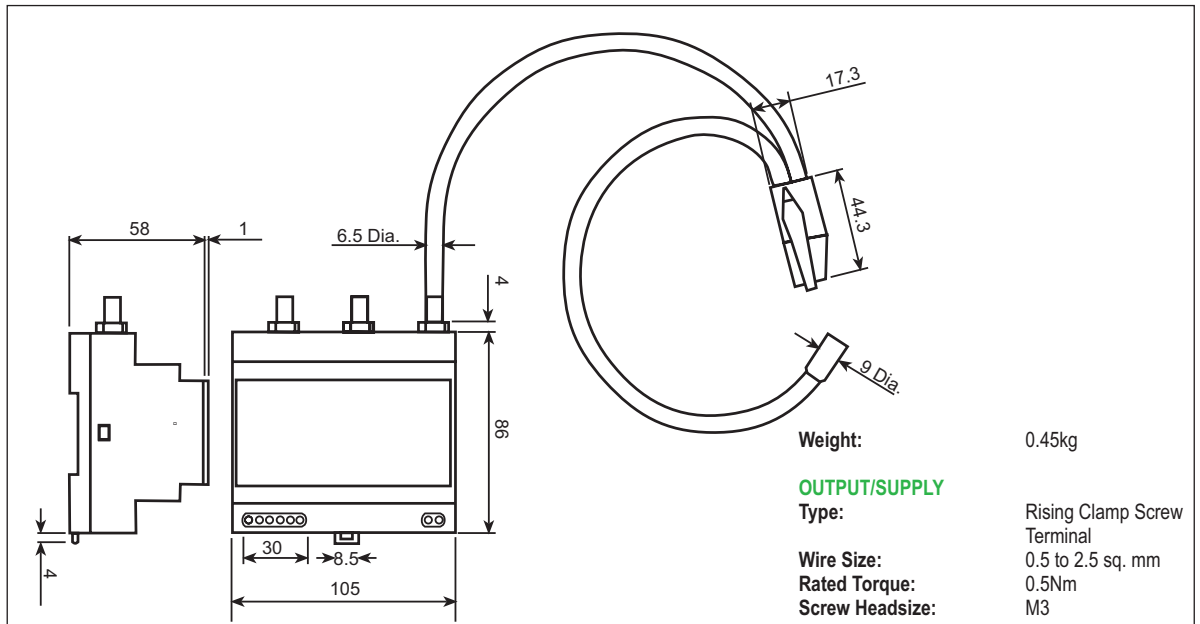

Further information

Further technical advice available at www.pemuk.com. For all questions, queries or specifications outside those listed please contact **Power Electronic Measurements Ltd.**



Power Electronic Measurements Ltd

Tel: 00 44 (0)115 9254212 • Fax: 00 44 (0)115 9677685 • Email: info@pemuk.com
Web: www.pemuk.com • Nottingham, UK

Available from July 2006